

# **INTERNATIONAL FINN CLASS RULES**



The Finn was designed in 1949 by Rickard Sarby and has been used at the Olympic Games since 1952.

## **2011 Edition**

# **INTERNATIONAL FINN CLASS RULES**

## **2011 Edition**

(Blank Page)

# INDEX

---

## INTRODUCTION

### PART I – ADMINISTRATION

#### Section A – General

A.1	Language .....	5
A.2	Abbreviations .....	5
A.3	Authorities and Responsibilities .....	5
A.4	Administration of the Class .....	5
A.5	ISAF Rules .....	6
A.6	Notice of Race and Sailing Instructions .....	6
A.7	Class Rules Amendments .....	6
A.8	Class Rules Interpretations .....	6
A.9	International Class Fee(s) and ISAF Hull Identification Sticker .....	6
A.10	Sail Numbers .....	7
A.11	Certification .....	7
A.12	Validity of Certificates .....	7
A.13	Compliance with Class Rules .....	7
A.14	Re-Certification .....	8
A.15	Old Boats .....	9

#### Section B – Boat Eligibility

B.1	Certificate .....	10
B.2	Certification Marks .....	10
B.3	Class Association Sticker .....	10

### PART II – REQUIREMENTS AND LIMITATIONS

#### Section C – Conditions for Racing

C.1	General .....	11
C.2	Crew .....	11
C.3	Personal Equipment .....	11
C.4	Advertising .....	11
C.5	Boat Equipment .....	12
C.6	Boat.....	13

C.7	Hull .....	13
C.8	Centreboard and Rudder.....	14
C.9	Rig .....	15
C.10	Sails .....	15

#### Section D– Hull

D.1	Parts .....	17
D.2	General .....	17
D.3	Hull .....	18
D.4	Deck .....	21
D.5	Buoyancy.....	21
D.6	Gunwale rubbing strakes .....	23
D.7	Floorboards or Double Bottom.....	23
D.8	Keelbands and Stemband .....	23
D.9	Assembled Hull .....	25

#### Section E –Centreboard and Rudder

E.1	General .....	31
E.2	Centreboard .....	31
E.3	Rudder Assembly .....	32

#### Section F – Rig

F.1	General .....	35
F.2	Mast .....	35
F.3	Boom .....	37

#### Section G – Sail

G.1	General.....	41
-----	--------------	----

### PART III – APPENDICES

<b>Appendix H.1</b>	- Certificate, measurement form, mast card and certification marks.....	45
---------------------	---	----

<b>Appendix H.2</b>	- Diagrams .....	46
---------------------	------------------	----

<b>Appendix H.3</b>	- Weight distribution and centre of gravity .....	49
---------------------	--	----

<b>Appendix H.4</b>	- Class rule amendments and interpretations .....	51
---------------------	--	----

# INTRODUCTION

---

*FINN hulls, hull appendages, rigs and sails are measurement controlled.*

*FINN mast spars and sails shall be measured before leaving the manufacturer. The rules provide an option for using an approved in-house measurer.*

*Owners and helmsmen should be aware that compliance with rules in Section C is NOT checked as part of the certification process.*

*Rules regulating the use of equipment during a race are contained in Section C of these class rules, in ERS Part I and in the Racing Rules of Sailing.*

# PART I – ADMINISTRATION

---

## Section A – General

### A.1 LANGUAGE

- A.1.1 The official language of the class is English and in case of dispute over translation the English text shall prevail.
- A.1.2 The word “shall” is mandatory and the word “may” is permissive.

### A.2 ABBREVIATIONS

- A.2.1 ISAF International Sailing Federation  
MNA ISAF Member National Authority  
IFA International Finn Association  
NFA National Finn Association  
ERS Equipment Rules of Sailing  
RRS Racing Rules of Sailing

### A.3 AUTHORITIES AND RESPONSIBILITIES

- A.3.1 The international authority of the class is the ISAF which shall co-operate with the IFA in all matters concerning these **class rules**.
- A.3.2 No legal responsibility with respect to these **class rules**, or accuracy of measurement, rests with:  
the ISAF,  
the MNA,  
the IFA,  
an NFA,  
the **certification authority**,  
an **official measurer**.

No claim arising from these **class rules** can be entertained.

- A.3.3 Notwithstanding anything contained herein, the **certification authority** has the authority to withdraw a **certificate** and shall do so on the request of the ISAF.

### A.4 ADMINISTRATION OF THE CLASS

- A.4.1 The administering authority is the IFA. Except as provided for under A.10.3, the **certification authority** is the NFA of the boat’s owner. The NFA may delegate part or all of its functions, as stated in these **class rules**, to a MNA.
- A.4.2 In countries where there is no NFA or MNA, or where neither of these wishes to administer the class, its administrative functions as stated in these **class rules** shall be carried out by the IFA.

## **A.5 ISAF RULES**

- A.5.1 These **class rules** shall be read in conjunction with the 2009 – 2012 ERS and RRS.
- A.5.2 Except where used in headings, when a term is printed in “**bold**” the definition in the ERS applies and when a term is printed in “*italics*” the definition in the RRS applies.

## **A.6 NOTICE OF RACE AND SAILING INSTRUCTIONS**

- A.6.1 At Events of World Championship Grade and of Grade 1, the Notice of Race/Sailing Instructions may vary these **class rules** only with the agreement of the IFA and the ISAF.
- A.6.2 At other Open Events, the Notice of Race/Sailing Instructions may vary these **class rules** only with the agreement of the NFA.

## **A.7 CLASS RULES AMENDMENTS**

- A.7.1 Amendments to these **class rules** shall be proposed by the IFA and require approval by the ISAF in accordance with the ISAF Regulations. The class procedure is at Appendix H.4.
- A.7.2 The Notice of Race or Sailing Instructions may state a higher recommended windspeed of 12 kts for rule C.1.1(2).

## **A.8 CLASS RULES INTERPRETATIONS**

### **A.8.1 GENERAL**

Interpretation of **class rules** shall be made in accordance with the ISAF Regulations. The class procedure is at Appendix H.4.

### **A.8.2 AT AN EVENT**

Any interpretation of **class rules** required at an event may be made by an international jury constituted in accordance with the RRS. The international jury should consult with the IFA Technical Committee and class representatives. Such interpretation shall only be valid during the event and the organising authority shall, as soon as practical after the event, inform the IFA, the MNA and the ISAF. The class procedure is at Appendix H.4.

## **A.9 INTERNATIONAL CLASS FEE(S) AND ISAF HULL IDENTIFICATION STICKER**

- A.9.1 The builder shall pay the International Class Fee on every hull built, whether or not it is subsequently measured and registered. Payment shall be made to the IFA, which will transfer the agreed amount to the ISAF.
- A.9.2 The IFA shall, after having received the International Class Fee for the hull, send the ISAF Hull Identification Sticker and a measurement form to the hull builder.
- A.9.3 The Hull Identification Sticker Number shall not be changed.

## A.10 SAIL NUMBERS

- A.10.1 Sail numbers shall be issued by the **certification authority**.
- A.10.2 Sail numbers shall be issued to all boats, in consecutive order starting at "1" for each national authority.
- A.10.3 Personal sail numbers may be issued by the **certification authority** in a sailor's home country. Personal sail numbers are additional to the sail numbers issued to all boats. If the use of a personal sail number is likely to cause confusion, a race committee may require that a boat use the sail number issued under rule A.10.2, or another agreed number.

## A.11 CERTIFICATION

- A.11.1 The Certification Documentation consists of a **certificate**, a class rule book, a completed measurement form, and mast card(s). If attachments are made to the **certificate**, this shall be noted on the main document.
- A.11.2 For a **hull** not previously **certified**, all items required by the measurement form to be measured shall be measured by an **official measurer** and the details entered onto the form.
- A.11.3 The measurement form, and **certification** fee if required, shall be sent to the **certification authority** in the country where the **hull** is to be registered after completion of measurement.
- A.11.4 Upon receipt of a satisfactorily completed measurement form, the **certification authority** shall issue a **certificate** and return the measurement form.
- A.11.5 The **certification authority** should retain a copy of the measurement form and **certificate**, which should be transferred to the new **certification authority** upon request if the **hull** is exported.
- A.11.6 The arrangements and formats for Certification Documentation and Certification Marks are described at Appendix H.1.

## A.12 VALIDITY OF CERTIFICATES

- A.12.1 A **certificate** becomes invalid upon:
- change of ownership,
  - withdrawal by the **certification authority**,
  - the issue of another **certificate**.

## A.13 COMPLIANCE WITH CLASS RULES

- A.13.1 A **boat** ceases to comply with the **class rules** upon:
- The use of equipment which does not comply with the **class rules**,
  - Alterations to the position, number or mass of weight correctors,
  - The use of equipment that does not comply, or that causes the **boat** not to comply, with limitations recorded on the **certificate**,
  - Alteration or repair to items required by the measurement form(s) to be measured, other than permitted routine maintenance,
  - A change of **class rules** that causes equipment in use to cease to be permitted, except as allowed under rule A.15.

## A.14 RE-CERTIFICATION

A.14.1 A **hull** may be re-certified by the issue of a new **certificate**, showing dates of initial and new **certification** as applicable:

- (a) WHEN A CERTIFICATE BECOMES INVALID UPON CHANGE OF OWNERSHIP

The new owner shall apply for re-certification by sending the old **certificate**, and fee if required, to the **certification authority** in the country where the hull is to be re-certified. If this **certification authority** is different from the previous **certification authority** then the new owner should also send the measurement form to the new **certification authority** for recording.

The new **certification authority** shall issue a new **certificate** with the cancelled certificate attached, and return the measurement form. It should retain a copy of the measurement form and **certificate**.

- (b) WHEN A CERTIFICATE HAS BEEN WITHDRAWN, OR WHEN THE CERTIFICATE AND MEASUREMENT FORM(S) CANNOT BE LOCATED

The owner shall arrange for **certification control** as required for initial **certification** and then apply for re-certification by sending the hull measurement form(s), and fee if required, to the **certification authority** in the country where the **hull** is to be re-certified.

A.14.2 A **boat** that has ceased to comply with its **certificate** may be brought into compliance:

- (a) WHEN THE LIMITATIONS AFFECTING THE EQUIPMENT ARE CONTROLLED BY THE CLASS RULES

By carrying out **certification control** of the affected equipment,

- (b) WHEN THE LIMITATIONS AFFECTING THE EQUIPMENT ARE ON THE CERTIFICATE

By carrying out **certification control** of affected equipment as required for initial **certification**, and complying with B.1.4 if relevant.

## A.15 OLD BOATS

- A.15.1 The following rules always apply: C.9.4, D.9 (except those related to gunwale rubbing strakes), E.2.5 (b), G.1.
- A.15.2 Subject to A.15.1, a **hull** or other equipment not complying with current **class rules**, but complying with the **class rules** in force at a previous **certification control**, may retain **certification**, provided that the non-compliance does not give a racing advantage to the **boat**.
- A.15.3 In particular, Rule A.15.2 can be applied with respect to centreboard thickness, centreboard coating, centreboard arm dimensions, centreboard weight, rudder hangings, gunwale rubbing strakes, mast centre of gravity, mast bearing diameters and boom attachment arrangement. If Rule A.15.2 is applied with respect to the boom attachment arrangement, then a mast **lower limit mark** must be made, complying with the older class rules (860 mm above the heel, width minimum 13 mm).
- A.15.4 Altered or renewed equipment shall comply with current **class rules** unless, in the opinion of the **certification authority**, this is unreasonable.
- A.15.5 All alterations involving removal of weight including correctors must be made under the supervision of an **official measurer**, who shall amend the **Certificate** and Measurement Form accordingly.
- A.15.6 Weight may be removed if the **hull** and **centreboard** are then re-weighed and retested together using the Lamboley Test.
- A.15.7 As an exception, If the initial distance  $\lambda$  is greater than 2110 mm, a simple magnetic compass and its mounting may be removed, and corrector weight may be removed from a position between 1000mm and 2100mm longitudinally from the Hull Datum Point. The **hull** with **centreboard** shall then be re-weighed. If the measurer has reasonable doubt about whether Rule D.9.3 (c) may be contravened, he shall require compliance with A.15.6.

## Section B – Boat Eligibility

For a **boat** to be eligible when *racing*, the rules in this section shall be complied with.

### B.1 CERTIFICATION

- B.1.1 The Certification Documentation specified in A.11.1 shall be held by the helmsman and shall be available upon official demand.
- B.1.2 The boat, all spars, sails and equipment shall have been measured by an **official measurer**, found correct, and the results entered upon the Measurement Form or Measurement Cards where appropriate.
- B.1.3 The hull shall have a valid **certificate** including **corrector weight** and related details as specified in C.7.2 and C.7.3.
- B.1.4 Any alteration to the information entered under B.1.3 shall be recorded on the **certificate** (or on an attachment) by an **official measurer**, who shall sign and date the alteration.

### B.2 CERTIFICATION MARKS

- B.2.1 The mast shall carry a valid sticker and have a valid mast card.
- B.2.2 The sail shall have a valid IFA sail label attached near the tack.
- B.2.3 The Centreboard, Rudder and Boom shall carry valid **certification marks**.

### B.3 CLASS ASSOCIATION STICKER

- B.3.1 The owner must be a member of IFA and the current year's IFA sticker must be fixed to the **hull** in a conspicuous position. The IFA sticker is the receipt for the yearly membership due paid to the IFA.

#### B.3 - IFA STICKER



## PART II – REQUIREMENTS AND LIMITATIONS

---

The **crew** and the **boat** shall comply with the rules in Part II when *racing*. Measurement to check conformity with rules of Section C is not part of **certification control**.

The rules in Part II are **closed class rules**. Measurement shall be carried out in accordance with the ERS except where varied in this part.

### Section C – Conditions for Racing

*Rules that are not part of certification control are placed in this section. The reason could be either that compliance with the rule could only be checked at an event or that checking requires access to one or more parts that are individually certified.*

#### C.1 GENERAL

##### C.1.1 RULES

- (1) RRS Rule 42.3 (c) is deleted and replaced with
  - (c) The race committee may signal in accordance with RRS P5 that pumping, rocking and ooching are permitted, after the starting signal and except on a beat to windward.
- (2) The Finn Class recommends that race committees apply Rule C.1.1 (1) in winds of 10 knots and above, measured at deck level on a race committee boat at the windward mark.
- (3) In accordance with RRS 43.1(b), the maximum weight for a competitor's clothing and equipment is increased from 8kg to 10kg.

#### C.2 CREW

##### C.2.1 LIMITATIONS

The **crew** shall consist of 1 person.

#### C.3 PERSONAL EQUIPMENT

##### C.3.1 TOTAL WEIGHT

See Class Rule C.1.1(3)

#### C.4 ADVERTISING

##### C.4.1 LIMITATIONS

Advertising shall only be displayed in accordance with the ISAF Advertising Code. (See ISAF Regulation 20)

## C.5 BOAT EQUIPMENT

### C.5.1 FOR USE

#### (a) **Mandatory**

- (1) Anchor and anchor warps if required by the Notice of Race and/or Sailing Instructions.

#### (b) **Optional**

- (1) Electronic or mechanical timing devices.
- (2) Magnetic compasses having no electronics.
- (3) One electronic self-contained compass, using magnetic input. If electronic, the compass may have only heading and timing functions. The display letters and numerals shall be not more than 30 mm high.

The display may show only the following:

- heading (damping may be adjusted manually),
- heading  $\pm$  a tacking angle (which may be adjusted manually),
- time,
- race timing information,
- identification,
- battery condition, system error, adjustment and calibration information.

Race timing information may be transmitted by sound. The electronic compass shall not deliver, store or correlate information in any way except as described here.

- (4) Other equipment and fittings normally carried in boats such as hand bailers, buckets, flags, mechanical wind indicators, anchors and anchor warps, fenders, bags, bottles, manual recorders, writing equipment and spares.

### C.5.2 NOT FOR USE

#### (a) **Mandatory**

- (1) Towing rope minimum 8 m long of not less than 8 mm in diameter, capable of floating.

#### (b) **Optional**

- (1) One paddle.

## C.6 BOAT

### C.6.1 FLOTATION

- (a) Buoyancy shall ensure that in the event of complete flooding, a fully rigged boat with intact buoyancy units will float approximately level.
- (b) It is the owner's responsibility to see that the buoyancy apparatus is kept securely fastened and fully effective when afloat. Hatch covers and drainage plugs for buoyancy units shall be kept in place at all times.
- (c) **Official Measurers**, Race Committees or Juries may require that a buoyancy test be satisfactorily completed at any time.

### C.6.2 LIMITATION

When this rule is invoked in the NoR or Sailing Instructions, the following equipment limitations shall apply:

Not more than 1 hull with 1 centreboard, 2 masts, 2 booms, 2 rudders and 2 sails may be used during an event. When an item has been lost or damaged beyond repair the race committee may approve additional equipment.

## C.7 HULL

### C.7.1 MODIFICATIONS AND MAINTENANCE

- (a) The hull shell, decks, bulkheads and double bottom (if fitted) shall not be altered in any way except as permitted by these **class rules**.
- (b) Holes not bigger than necessary for the installation of fittings and passage of lines may be made in decks and bulkheads, but not for the passage of lines through buoyancy units.
- (c) Routine maintenance such as painting and polishing is permitted without re-measurement and re-**certification**.
- (d) If any hull moulding is repaired in a way that might cause Rules C.6.1 or D.9 to be contravened, an **official measurer** shall satisfy himself that the equipment remains within the rules. The **official measurer** shall also describe the details of the repair on the **certificate**.

### C.7.2 WEIGHT AND WEIGHT DISTRIBUTION

After completion of **certification control**, if fittings or other items are moved in a way that might cause Rules D.9.2 and D.9.3 to be infringed, Rule A.13.1 shall apply and a new **certification control** under Rules D.9.2 and D.9.3 is required.

### C.7.3 FITTINGS

- (a) The **mast** bearings may be adjustable for position fore and aft when not *racing*, but any adjustable or movable part, whether permanently part of the step or not, shall always be forward of Station 7.
- (b) The fore-and-aft movement at the masthead due to play at the deck and heel bearing systems, shall not exceed the amount measured as follows:  
With the boat held stern down, a light line shall be rigged at a constant tension from the masthead halyard sheave to the top of the transom. The **mast** shall be pushed maximum forward and maximum aft to take

up play at the bearings. The difference in the distance from the masthead to the transom shall not exceed 10 cm.

- (c) Hiking pads, attached to but removable from the **hull** are permitted. They shall extend not more than 10 mm outboard of the vertical plane of the gunwale rubbing strake.
- (d) Standing rigging is prohibited.
- (e) Other fittings are permitted, subject to:
  - (1) The fitting shall cause no other rule to be infringed.
  - (2) It shall be possible to remove a fitting without damaging the structure.
  - (3) Holes and recesses may be cut to receive a fitting.
  - (4) Fittings shall have a reasonable weight, which must not be for the alteration of the boat's weight distribution.
  - (5) Fittings having a significant effect on the **hull** weight distribution shall be recorded on the measurement **certificate**.

## **C.8 CENTREBOARD AND RUDDER**

### **C.8.1 MAINTENANCE**

Routine maintenance such as painting and polishing is permitted without remeasurement and re-**certification**.

### **C.8.2 LIMITATIONS**

- (a) Only one **centreboard** shall be used during an event, except when a **centreboard** has been lost or damaged beyond repair.
- (b) See C.6.2.

### **C.8.3 CENTREBOARD**

#### **(a) Use**

There shall be an arrangement to prevent the **centreboard** from retracting completely if the boat is upside down.

### **C.8.4 RUDDER**

#### **(a) Use**

- (1) There shall be a fitting to prevent the **rudder** from falling off if the boat is upside down.
- (2) Except as allowed in (3) below, lifting rudder blades shall be pinned or bolted so that the rudder assembly complies with E.3.4.
- (3) A NA or Race Committee may allow lifting of the rudder blade if local conditions justify it and it is clearly stated in the Notice of Race and the Sailing Instructions.

**C.9 RIG****C.9.1 MAINTENANCE**

Routine maintenance such as painting and polishing is permitted without re-measurement and re-**certification**.

**C.9.2 LIMITATIONS**

See C.6.2.

**C.9.3 MAST****Use**

- (1) The **spar** shall be fitted in such a way that it will not come out of the step when the boat is capsized.
- (2) Except for normal sail controls, arrangements to introduce pre-bend or twist, or to vary the stiffness of a mast during the race are prohibited.

**C.9.4 BOOM**

- |   |  |         |         |
|---|--|---------|---------|
| <b>(a) Dimensions</b>                           |  | minimum | maximum |
| <b>Limit mark width</b> .....                   |  | 13 mm   |         |
| <b>Boom Outer Point</b> from aft edge line..... |  | 3270 mm |         |

**(b) Use**

- (1) The boom shall be fitted to the mast so that all parts rotate together. Arrangements allowing over rotation of the mast are prohibited.
- (2) Mainsheet and Mainsheet block attachments on the boom allowing additional athwartship travel are prohibited.
- (3) A stop shall be fitted so that rule C.10.3 (d) cannot be contravened.

**C.10 SAILS****C.10.1 MODIFICATION, MAINTENANCE AND REPAIR**

- (a) Routine repairs and maintenance are permitted without re-measurement and re-**certification**.
- (b) As an exception to G.1.4 (b), for winners of the Finn Gold Cup and for Olympic Gold Medallists in the Finn Class, the sail insignia waves may be coloured Gold.

**C.10.2 LIMITATIONS**

See C.6.2.

**C.10.3 USE**

- (a) The **sail** shall be hoisted on a halyard. The arrangement shall permit hoisting and lowering of the **sail** at sea.
- (b) **Luff** and **foot** boltropes shall be in the **spar** grooves or tracks.
- (c) The highest visible point of the **sail**, projected at 90° to the mast **spar**, shall not be set above the mast **upper point**.
- (d) The aftmost visible part of the **sail**, projected at 90° to the boom **spar**, shall not be set outboard of the boom **outer point**.

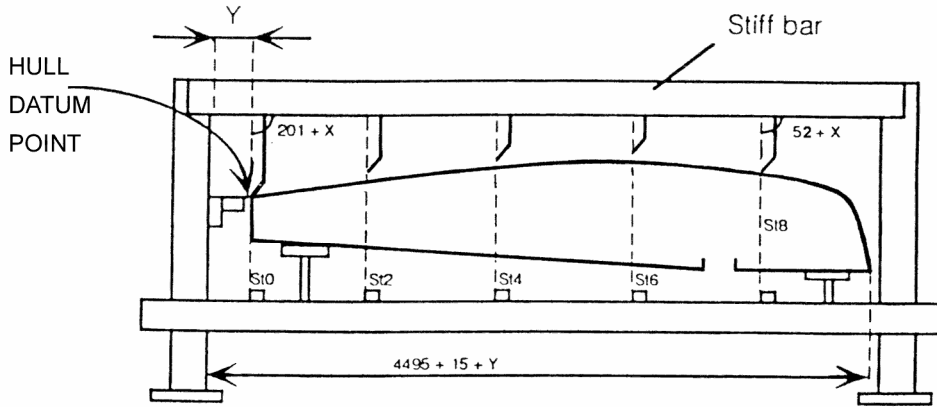

Section D - Principles of hull measurement when using a jig

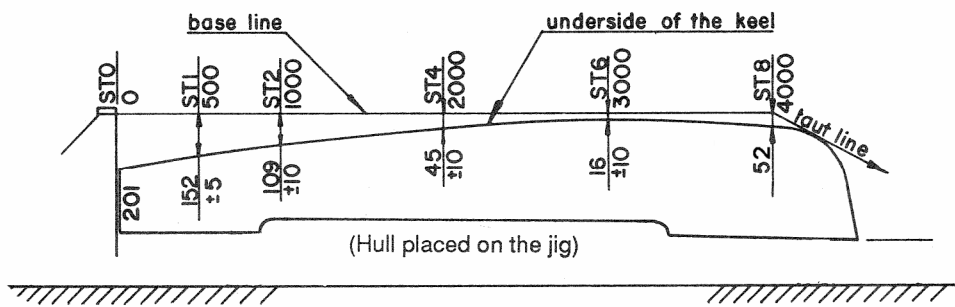

Section D - Keel Profile

D.3.2 and D.9.1 - Radius at concave corners; thwart and centreboard case dimensions.

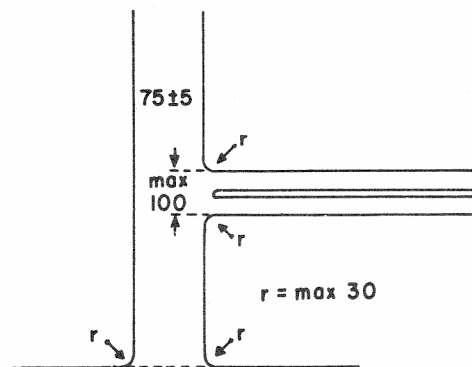

## Section D – Hull

### D.1 PARTS

#### D.1.1 MANDATORY

- (a) Hull shell
- (b) Deck
- (c) Thwart
- (d) Buoyancy units
- (e) Gunwale rubbing strakes
- (f) Floorboards or double bottom
- (g) Keel bands

#### D.1.2 OPTIONAL

- (a) Bulkheads
- (b) Centreboard case athwartship stiffening struts
- (c) Mainsheet Traveller tracks and supports below sheer height

### D.2 GENERAL

#### D.2.1 CERTIFICATION

The **hull** and **centreboard** shall be measured together, and details shall be recorded upon the measurement form and **certificate** as specified by Rule A.11. If a new **centreboard** is fitted, then **certification control** is required under Rule D.9, and measurement under E.2.5 (b).

#### D.2.2 DEFINITIONS

- (a) The three major axes of the boat at 90° to each other – vertical, longitudinal and transverse, shall be related to the baseline and the **hull** centreplane. The terms “above” and “below” assume that the hull is upright.
- (b) Hull Datum Point  
The intersection, on the centreplane of the **hull**, between the underside of the shell (excluding keelband if fitted) and the transom.
- (c) Baseline  
The measurement baseline shall be on the centreplane of the hull at the following vertical distances:
  - (1) 201 mm below the hull datum point.
  - (2) at Station 8 : 52 mm below the keelband.
- (d) Stations  
With the baseline horizontal, the Measurement Stations are the vertical planes normal to the baseline, with Station 0 at the hull datum point, Station 1 at 500 mm forward of the hull datum point, Station 2 at 1000 mm forward of the hull datum point, and so on.

- (e) **Hull length** is the distance parallel to the baseline from the plane of station 0 to the outside of the stemband, excluding any gunwale rubbing strake.
- (f) The Stem Template Datum Point is at the underneath of the keelband/stemband, at a position forward or aft of Station 8 by the amount that the hull length is greater or less than 4495mm.

### D.2.3 BUILDERS

- (a) The Finn may be built by any professional or amateur builder
- (b) Professional builders shall be responsible for supplying boats or kits complying with the Finn Class Rules. The builder shall, at his own expense, correct or replace any boat that fails to pass **certification control**, due to omission or error by the builder, provided that the boat is submitted for **certification control** within 12 months of purchase.

### D.2.4 IDENTIFICATION

The ISAF Hull Identification Sticker prescribed by Rule A.9 shall be permanently placed in a visible spot on the centreboard case or on the aft bulkhead of the cockpit.

## D.3 HULL

### D.3.1 MATERIALS

The hull shell and structural panels including tank sides, decks, floorboard or inner bottom, thwart, centreboard case and bulkheads shall be made from wood or glass reinforced plastic, except that additional stiffening and local reinforcement may be of any material.

### D.3.2 CONSTRUCTION

- (a) The concave corners where hull panels, deck, thwart, centreboard case and bulkheads meet may be rounded to a radius of not more than 30 mm.
- (b) If the centreboard pivot pin is movable, it must not allow Rule E.2.5 (b) to be contravened. It must not be moved during a race. For **certification control** under Rules D.9.2 and D.9.3, the centreboard pivot pin must be in its aftmost position.
- (c) The pivot pin shall pass through the walls of the centreboard case.
- (d) Longitudinal tapering and rocking points on the centreboard box are prohibited.
- (e) Centreboard box sealing strips are prohibited.
- (f) From Station 0 to Station 6, hollows in the hull form are prohibited. From Station 6 to the Stem, hollows in the plane of the Sections are prohibited. Minor distortion due to curing of plastic hulls is acceptable.
- (g) Except at the sides of the keelband position, knuckles and chines are prohibited.

(Blank Page)

D.4 - Setting up the hull for cockpit measurement

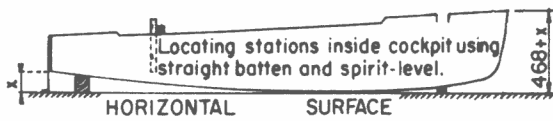

D.4 - Deviation of the top of the deck at centreplane from a straight line between the stemhead and St.0.

Limit of variation from a taut line is  $(x \pm 10\text{mm})$ .

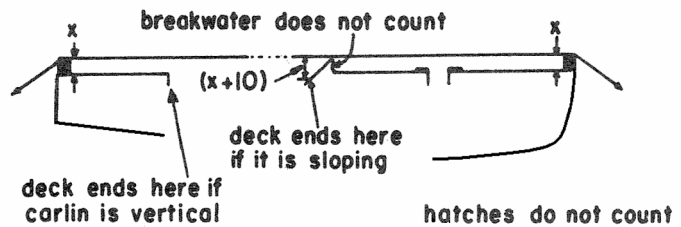

D.4 - Cockpit minimum width

p and q are examples showing the distance from centreplane to side decks or built in tanks.

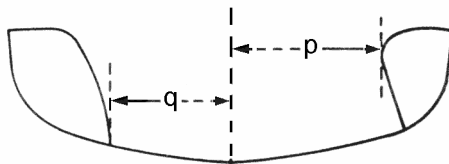

D.4 - COCKPIT MAXIMUM WIDTH

Distance from centreplane to side decks or built in tanks at some point between the sheer and 100 mm below the sheer

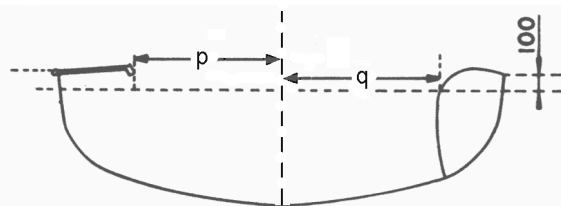

## D.4 DECK

### D.4.1 CONSTRUCTION

- (a) The shapes of the decking and built in tanks (if fitted) shall be approximately the same on both sides of the boat.
- (b) The general arrangement of the decking and cockpit shall be substantially as shown in the plans except as varied by these rules.
- (c) The ends of the cockpit may be either straight across the boat or faired into the side decks.
- (d) Pads and recesses to mount or locate fittings are permitted, but not at the **sheerline**.

## D.5 BUOYANCY

### D.5.1 DEFINITION

- (a) Buoyancy units are bags, tanks or foam blocks enabling compliance with D.5.2, D.5.3 and C.6.1.
- (b) A tank having holes for running rigging or for the mast is not a buoyancy unit.
- (c) Other buoyancy may be fitted, providing that no other rule is infringed.

### D.5.2 CONSTRUCTION

- (a) At least 4 separate buoyancy units shall be fitted, so that the flooded **boat** can satisfy the buoyancy requirements of D.9.1.
- (b) Every buoyancy tank shall be fitted with an inspection hatch.
- (c) Buoyancy tanks may be fitted with drain holes. If so, they shall be capable of being securely plugged.
- (d) There shall be no surplus buoyancy within the cockpit area above the floorboards, except that flexible bags may bulge within this area as long as their main volume and their anchorages for the fixation straps are outside it.

### D.5.3 INSPECTION AND TESTING

- (a) The measurer shall satisfy himself that the buoyancy units and arrangement are effective to ensure compliance with D.5.2 (a) and (b), also with C.6.1.
- (b) In deciding whether a buoyancy test is required under this Rule or under Rule C.6.1, a measurer may take account of certified compliance with the pressure drop tests prescribed in ISO 12217-3:2002 Annex C.

### D.6 - Gunwale rubbing strakes

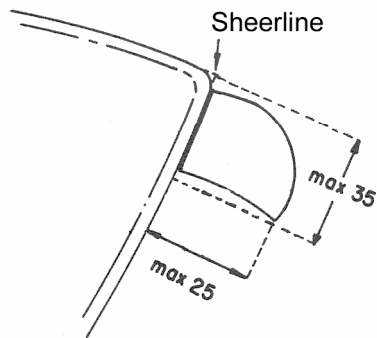

---

### D.8 - Keel bands and stem band.

D.8.1 (c) and (d): Fairing and padding are not allowed for the keel bands, but are allowed for the stem band forward of Station 8. The stem band radius must not be less than 6 mm.

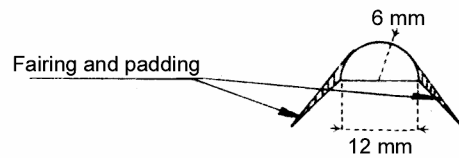

## D.6 GUNWALE RUBBING STRAKES

### D.6.1 MATERIALS

The gunwale rubbing strakes may be made from any resilient material. They may be formed as part of the hull.

### D.6.2 CONSTRUCTION

- (a) Gunwale rubbing strake dimension minima are not applicable within 100 mm of the stem and 100 mm of station 0.
- (b) Gunwale rubbing strakes may be rounded on the outside and hollowed on the underside.
- (c) Gunwale rubbing strakes must be capable of supporting the boat for the pendulum test.

## D.7 FLOORBOARDS OR DOUBLE BOTTOM

### D.7.1 CONSTRUCTION

- (a) The floorboards shall extend at least from station 4 to the aft end of the cockpit. They shall lie in a straight line athwartships and have sufficient support to enable them to remain substantially flat when under load.
- (b) The floorboards may be pierced with holes totalling not more than 10% of their nominal area.
- (c) The floorboards may be part of the hull to form a double bottom.

### D.7.2 OPTIONAL

Forward of Station 4, floorboards if fitted need not comply with D.7.1 (a) and (b).

## D.8 KEEL BANDS AND STEM BAND

### D.8.1 CONSTRUCTION

- (a) The keel bands are optional from Station 0 to the forward end of the Centreboard Slot
- (b) Forward of the Centreboard slot the stem band and keel band are compulsory
- (c) Between Station 0 and 8 Bands where fitted shall be made separately from the **hull**.
- (d) Between Station 8 and the top of the stem, the stem band may be part of the **hull**, and may be faired into the **hull**.
- (e) The forward keel band may be tapered vertically for up to 25mm from the forward end of the centreboard slot.

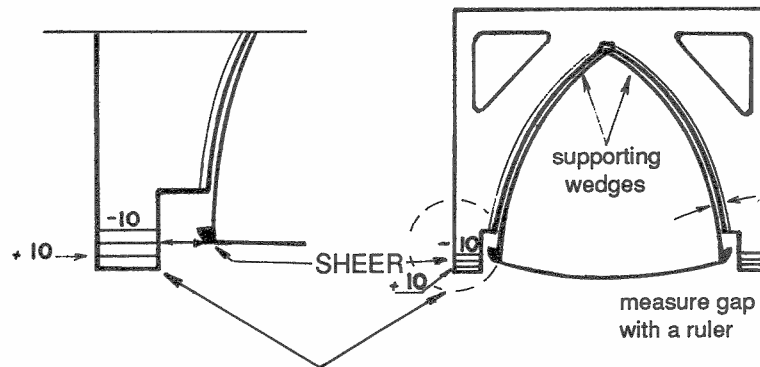

Section D.9.1 - Hull shape measured with templates

Rule D.9.1 - Checking stem profile with the template

The example shows how to set up the stem template on a boat of maximum length. The template tabs shall touch the stem band; the sheer shall lie within the tolerance; and the gap between stem band and template shall not be more than 10 mm.

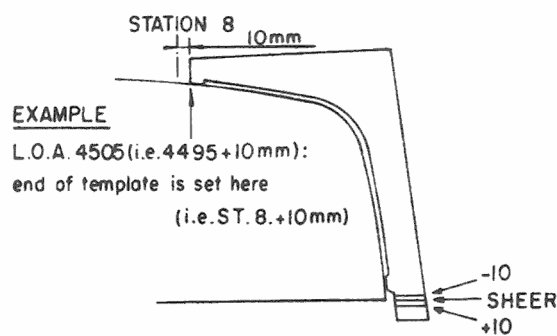

## D.9 ASSEMBLED HULL

### D.9.1 DIMENSIONS

	minimum	maximum
<b>Hull length</b> .....	4480 mm	4510 mm
Transom forward of Station 0: .....	0 mm	5 mm
Baseline below <b>hull</b> shell:		
at station 1 .....	147 mm	157 mm
at station 2 .....	99 mm	119 mm
at station 4 .....	35 mm	55 mm
at station 6 .....	6 mm	26 mm
Stem profile (outside stem band) to template: .....	0 mm	10 mm
<b>Sheer</b> above position marked on stem template: .....	-10 mm	+10 mm
Keel Band Section radius (half round) .....	6 mm	
Stem Band (forward of Section 8) radius .....	6 mm	
Centreboard Case;		
slot width .....	8 mm	12 mm
overall width .....	100 mm	
centre of centreboard pivot pin above underside of keel	40 mm	50 mm
Fore and aft adjustment for centreboard pivot pin .....	20 mm	
<b>Hull</b> shell to <b>hull</b> template:		
at station 0, 2, 4, 6 and 8 .....	0 mm	10 mm
<b>Sheerline</b> above position marked on template:		
	(Port)	(Starboard)
	minimum	maximum
at station 0, 2, 4, 6 and 8 ...	-10 mm	10 mm
.....	-10 mm	+10 mm
Length of foredeck .....	1350 mm	1450 mm
Length of aft deck .....	550 mm	650 mm
Distance between side decks or built in tanks and the centreplane:		
	minimum	maximum
at station 2 .....	410 mm	
at station 3 .....	500 mm	
at station 4 .....	490 mm	
at station 5 .....	440 mm	
Distance between side decks or built in tanks and the centreplane, at some point between the <b>sheerline</b> and 100mm below the <b>sheerline</b> :		
	minimum	maximum
at station 2 .....	520 mm	
at station 3 .....	560 mm	
at station 4 .....	550 mm	
at station 5 .....	500 mm	

D.9.1 - Height of mast step above  
underside of keel band

$$\left(\frac{a+b}{2}\right) - c \text{ is maximum } 56 \text{ mm}$$

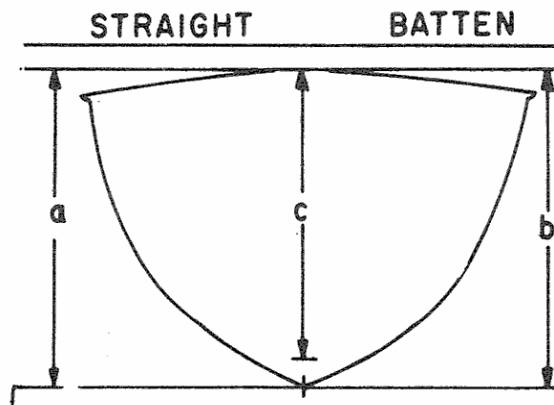

	Minimum	maximum
Top of the deck at centreplane above the <b>sheer</b>		
at station 0 .....	45mm	55 mm
Top of the deck at centreplane above a straight line between the stemhead and station 0 (excluding breakwaters, hatches, cockpit coamings and mast deck bearing arrangements) .....	-10 mm	10 mm
Pads or recesses to mount or locate fittings .....	-10 mm	10 mm
Buoyancy: Support provided by flooded boat;		
with buoyancy units intact.....	120 kg	
with any one buoyancy unit flooded .....	90 kg	
Inside diameter of buoyancy tank inspection holes .....	95 mm	
Gunwale rubbing strakes;		
depth (down from the <b>sheerline</b> around the <b>hull</b> ) .....	20 mm	35 mm
width (at a right angle to the shell).....	20 mm	25 mm
Width of floorboards;		
at station 2 .....	800 mm	
at station 3 .....	880 mm	
at station 4 .....	720 mm	
Floorboards or double bottom below <b>sheer</b> ;		
At station 2 .....	285 mm	
At station 3 .....	325 mm	
At station 4 .....	375 mm	
At station 5 .....	If fitted	375 mm
At station 6 .....		390 mm
Thwart;		
depth .....	16 mm	50 mm
width .....	70 mm	80 mm
aft side forward of station 0 .....	1950 mm	2050 mm
top of thwart below <b>sheer</b> .....		130 mm
Mainsheet traveller block (centreline of attachment);		
Travel from centreplane of boat .....	550 mm	
Travel forward of station 4 .....	150 mm	
Height of mast heel above underside of Keel Band.....	56 mm	
Height of mast bearing surface above deck.....	10 mm	
Horizontal play in bearings.....	5 mm	
Number of holes in the transom.....	4	
Diameter of 2 largest transom holes.....	150 mm	
Diameter of 2 other holes .....	30 mm	
Bearing at Transom Pintle above <b>hull datum point</b> .....	52 mm	57 mm
Bearing at Transom Gudgeon above <b>hull datum point</b> .....	262 mm	267 mm
Axis of Transom Pintle aft of Station 0 ( $\alpha$ ) .....	10 mm	30 mm
Axis of Transom Gudgeon aft of Station 0 ( $\beta$ ) .....	10 mm	30 mm
Difference between ( $\alpha$ ) and ( $\beta$ ) .....	2 mm	
Diameter of Pintle and of Gudgeon Hole .....	7.9 mm	8.1 mm

D.9.2 WEIGHT

**(a) Condition for weighing**

For the purpose of Rules D.9.2, D.9.3 and D.9.4, the weighing condition for the assembled **hull** with **centreboard** installed is as follows:

- (1) If the Centreboard Pin, Mast Step and Deck bearing are movable, they shall be in their maximum aft positions.

The weight shall be taken

- (2) including **centreboard**, hiking pads, compass mountings and magnetic compasses having no electronics, other fittings, securely fastened containers, and normal ropes, but
- (3) excluding timer, electronic compass, rudder assembly, mainsheet and painter.
- (4) The **hull**, fittings and ropes shall be in a dry condition.
- (5) Control lines shall be pulled tight and wrapped around the thwart.
- (6) The **centreboard** shall be raised so that its lower corner is level with the underneath of the hull (keel bands excluded).

**(b) Weight** minimum maximum

The weight of the **hull** and **centreboard** in dry condition . 116.0 kg

D.9.3 HULL WEIGHT DISTRIBUTION AND CENTRE OF GRAVITY

- (a) See Appendix H.3 for details of the Hull Weight Distribution and Centre of Gravity Measurement.

- (b) The following measurements shall be taken;

- (i) Distance  $\lambda$  from the centre of gravity to Station 0.
- (ii) Distance d of axis  $O_1$  to the underneath of the keel (keel bands excluded).
- (iii) Periods of oscillations:  $T_1$  around axis  $O_1$ .  $T_2$  around axis  $O_2$ .

(c) **Dimensions** minimum maximum

Distance $\lambda$ .....	2100 mm	2290 mm
Distance h from underneath the hull (keel bands excluded) to the centre of gravity (see H.3).....	210 mm	
Radius of gyration $\rho$ .....	1100 mm	

D.9.4 CORRECTOR WEIGHTS

- (a) Lead **Corrector weights** shall be securely fastened to the **hull** if necessary to ensure compliance with D.9.2 and D.9.3. **Corrector weights** shall be visible to allow for inspection without the use of tools.

- (b) The total weight of such **corrector weights** shall not exceed 5 kg. The number, position and size of the hull **corrector weights**, and notes of other fittings (such as compasses and hiking pads) having a significant effect upon compliance with D.9.2 and D.9.3, shall be entered on the **certificate**.

(Blank Page)

E.2.5 (a). CENTREBOARD DIMENSIONS

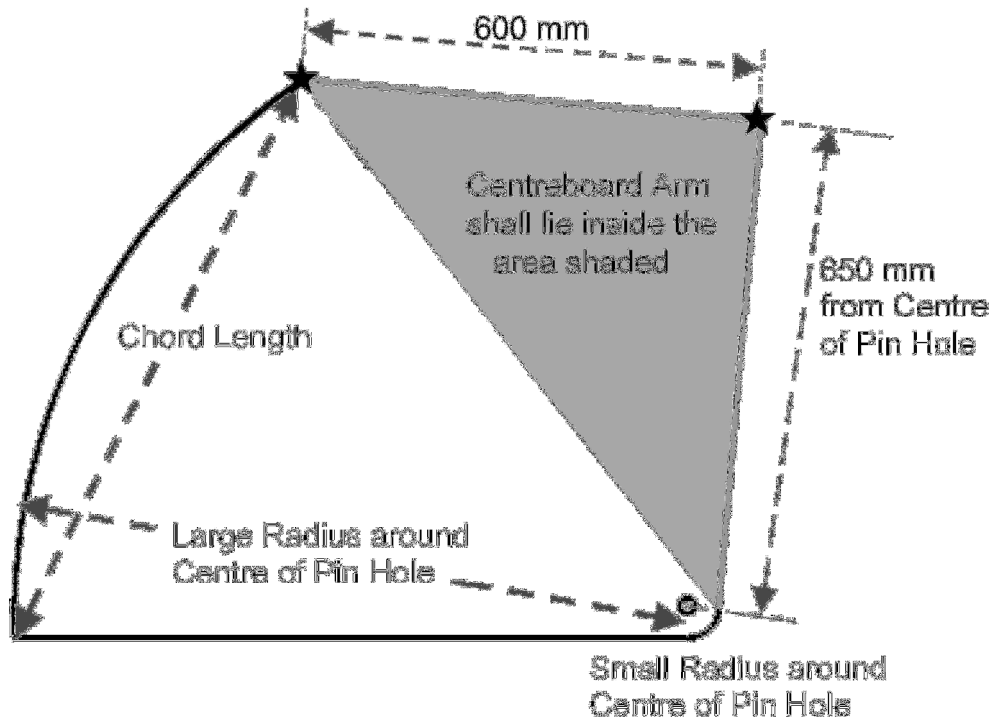

E.3.4 -  
Rudder Dimensions

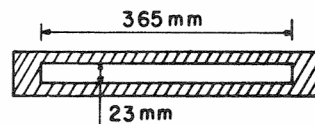
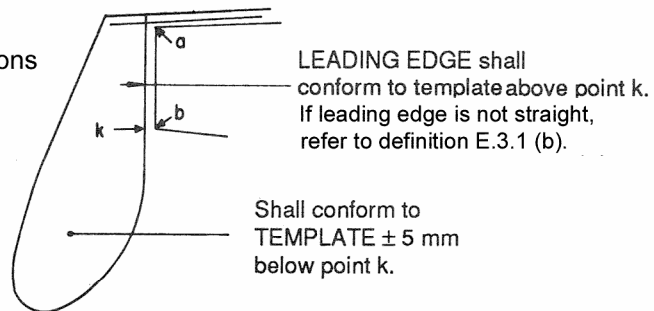

RUDDER GAUGE for thickness cut in 6 mm aluminium plate

## Section E – Centreboard and Rudder

### E.1 GENERAL

#### E.1.1 CERTIFICATION

An MNA may appoint one or more persons at a manufacturer to measure and **certify hull appendages** produced by that manufacturer in accordance with ISAF guidelines.

#### E.1.2 MANUFACTURERS

Rule D.2.3 applies to **hull appendages**.

### E.2 CENTREBOARD

#### E.2.1 DEFINITION

The Centreboard theoretical reference point is where the straight line extension of the leading edge meets the largest radius measured.

#### E.2.2 CERTIFICATION

- (a) Each **centreboard** shall have its own identifying number, which may be incorporated with the **certification mark**.
- (b) The **official measurer** shall **certify centreboards** by fixing, signing and dating a **certification mark** on the centreboard arm, visible in the raised position.
- (c) The **certification mark** shall be a durable numbered sticker produced under the authority of the IFA, or an **official measurer's** personal mark..

#### E.2.3 MATERIALS

- (a) The **centreboard** shall be of aluminium alloy of 8 mm nominal thickness, except that the leading and trailing edges may be shaped.
- (b) The **centreboard** may be anodised or coated with a clear coating.
- (c) Fibre and opaque reinforcement are permitted only to repair corrosion and other damage.

#### E.2.4 FITTINGS

##### (a) **Mandatory**

- (1) A stop to prevent the **centreboard** from contravening rule E.2.5 (b).
- (2) The **centreboard** shall have a hole to accept the centreboard pivot pin.

E.2.5 DIMENSIONS

(a) **Centreboard**

The Centreboard Arm shall fit within the area shown in the diagram.

	minimum	maximum
Large Radius .....	885 mm	..895 mm
Small Radius.....	30 mm	... 40 mm
Chord Length.....	815 mm	. 825 mm
Thickness.....	8 mm	.....8 mm
Edge shaping distance .....		... 25 mm

(b) **Centreboard fitted in hull**

Hole diameter larger than pivot pin diameter .....	0 mm	.....2 mm
Centreboard theoretical reference point below <b>hull</b> shell (excluding keelbands).....		...700 mm
Distance from <b>hull datum point</b> to aft edge of partially or fully extended <b>centreboard</b> , measured along the <b>hull</b> shell .....	2050 mm	
Projection below <b>hull</b> shell when fully raised .....		.....0 mm

E.2.6 WEIGHT

	minimum	maximum
.....	11 kg	..... 13 kg

**E.3 RUDDER ASSEMBLY**

E.3.1 DEFINITIONS

- (a) Point “k” is the leading edge at the waterline position taken from the **rudder** template.
- (b) The leading edge above point “k” is a line passing through point “k”, running parallel to the main axis of the **rudder** gudgeon and pintle upwards to deck level.

E.3.2 CERTIFICATION

- (a) Each **rudder** shall have its own identifying number, which may be incorporated with the **certification mark**.
- (b) The **official measurer** shall **certify** rudders by fixing, signing and dating a **certification mark** on the side of the rudder stock.
- (c) The **certification mark** shall be a durable numbered sticker produced under the authority of the IFA, or an **official measurer’s** personal mark.

E.3.3 MATERIALS

- (a) Materials for rudder construction are free.

E.3.4 DIMENSIONS

	minimum	maximum
Distance from leading edge to the rudder template Above point k .....	0 mm	0 mm
Distance from the edge to the rudder template Below point k .....	-5 mm	5 mm
Thickness of Rudder blade below point k .....		23 mm
Bearing at Rudder Gudgeon above point k.....	52 mm	57 mm
Bearing at Rudder Pintle above point k .....	262 mm	267 mm
Point k aft from Axis of Rudder Gudgeon and Pintle .....	10 mm	15 mm
Diameter of Gudgeon Hole and of Pintle .....	7.9 mm	8.1 mm

E.3.5 WEIGHTS

	minimum	maximum
(a) Overall weight of <b>rudder</b> , tiller, extension and fittings .....		4 kg
(b) Lead Corrector weights shall be securely fastened external to the rudder if necessary to ensure compliance with E.3.5 (a).		
(c) The total weight of such <b>corrector weights</b> .....		1 kg

### F.2.6 - Mast cross-section dimensions

Mast fore-and-aft shall not exceed the dimensions from the formula

Mast width shall not be less than the dimensions from the formula

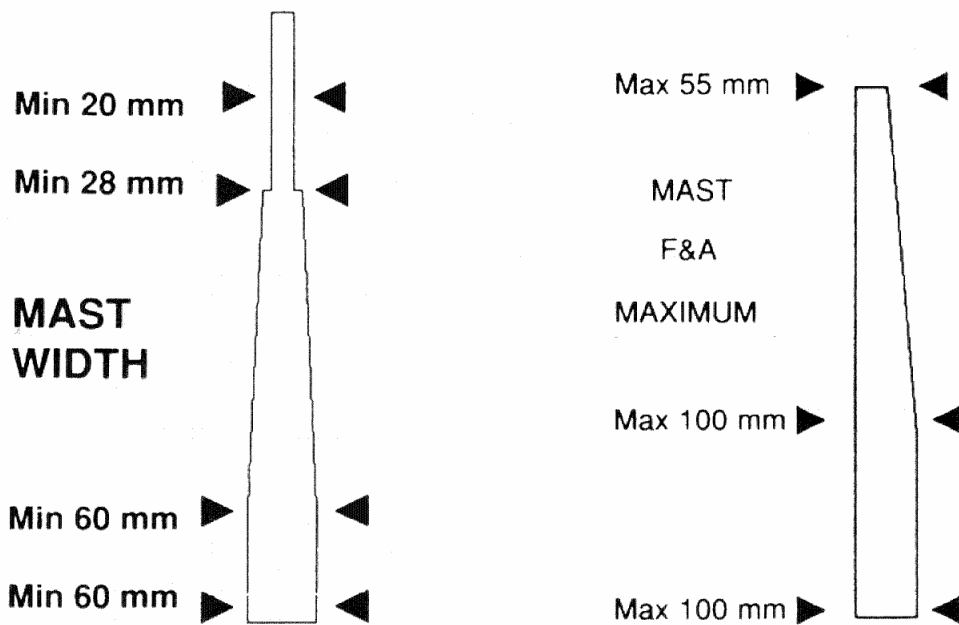

## Section F – Rig

### F.1 GENERAL

#### F.1.1 CERTIFICATION

An MNA may appoint one or more persons at a manufacturer to measure and **certify spars** produced by that manufacturer in accordance with ISAF guidelines.

#### F.1.2 MANUFACTURERS

Rule D.2.3 applies to **spars**.

### F.2 MAST

#### F.2.1 DEFINITIONS

(a) **Mast Spar.**

As defined in ERS. An attached or glued on sail track is part of the **spar**.

(b) **Main central axis.**

The **main central axis** of the **spar** shall be taken as a straight line passing through the following points;

- (i) Centre of the heel bearing
- (ii) Point 20 mm forward of the aft edge at the **upper point**

(c) **(Mast) heel (point)** is the lowest point of the mast.

(d) **Aft edge line.**

The aft edge of the mast between the upper point and the point where the sail leaves the mast, and its extensions. Fittings or built-in fairleads where the sail leaves the mast shall be disregarded. Any **mast spar curvature** shall be removed when taking measurements depending on the aft edge line.

#### F.2.2 CERTIFICATION

(a) **Masts** shall be measured by an **official measurer** before leaving the **mast** builder's premises.

(b) Every **mast** shall have a numbered IFA Mast Label attached within 1 metre above the deck bearing.

(c) Every **mast** shall have a Mast Measurement Card, approved by the IFA as complying with the requirements of Appendix H.1.3.

(d) The **official measurer** shall sign and date the IFA Mast Label, and shall **certify masts** by completing the Mast Measurement Card.

F.2.3 MATERIALS

- (a) The **spar** shall be made of wood, fibre reinforced plastic, aluminium alloy or a combination of these materials.
- (b) Anodising and protective coatings are allowed.
- (c) Plastic extruded sail track is allowed.
- (d) Fastenings may be of any material.

F.2.4 CONSTRUCTION

- (a) Holes shall be provided so that water drains readily from near the heel of the **spar**.
- (b) Flexible fairings are prohibited

F.2.5 FITTINGS

(a) **Mandatory**

- (1) Rigidly attached or integral mast bearing surfaces.
- (2) A fork fitting shall be rigidly attached to the mast, to accept the boom.
- (3) The whole top of the spar above the **upper point** shall be painted a distinctive colour.
- (4) **Corrector weights**, if fitted, shall be made of lead, and securely fastened to the outside of the mast above deck level.
- (5) EITHER a stop shall be fitted so that Rule C.10.3 (c) cannot be contravened  
OR a halyard lock arrangement fitted within 1m of the **upper point** shall be used

(b) **Optional**

- (1) Mechanical wind indicators.
- (2) Cleats, fairleads, lead blocks, halyard lock, halyard crane and other arrangements for halyard and control lines.

F.2.6 DIMENSIONS

- (a) The **mast spar** fore-and-aft cross-section, including sail track but not deck ring nor other fittings shall not exceed
  - (1) From **heel** to 2060 mm above the **heel**: 100 mm; thence
  - (2) A uniform taper to 55 mm at 6560 mm above the **heel**.

*Example fore-and-aft dimensions;*

<u>Distance from heel</u> .....	<u>maximum</u>
2060 mm .....	100 mm
2560 mm .....	95 mm
3560 mm .....	85 mm
4560 mm .....	75 mm
5560 mm .....	65 mm
6560 mm .....	55 mm

- (b) The **mast spar** transverse cross-section shall be not less than
  - (1) From below the **heel bearing** to 1000 mm above the **heel**: 60 mm;
  - (2) From (**heel** +1000 mm) a uniform taper from 60 mm to 28 mm at (**heel** + 5000 mm)
  - (3) From (**heel** + 5000 mm) to (**heel** + 6573 mm): 20 mm

*Example transverse dimensions;*

<u>Distance from heel</u> .....	<u>minimum</u>	
10 mm .....	60 mm	
1000 mm .....	60 mm	
2000 mm .....	52 mm	
3000 mm .....	44 mm	
4000 mm .....	36 mm	
5000 mm .....	28 mm	
		minimum maximum

- (c) Distance from **main central axis** to outer surface of **mast** or mast bearings (excluding other fittings) ..... 60 mm

(d) Other Dimensions:

<b>Upper point</b> height.....	6560 mm
Depth of extruded sail track (if fitted) .....	20 mm
Diameter of <b>mast</b> heel bearing .....	62 mm ..... 64 mm
Diameter of <b>mast</b> deck bearing .....	102 mm ... 104 mm
Width between arms of the boom fork fitting .....	37 mm ..... 40 mm
Centre of boom pin holes in fork fitting above heel.....	820 mm
Centre of boom pin holes aft of the aft edge line .....	40 mm
Diameter of boom pin holes.....	15.5 mm .. 16.5 mm
<b>Mast spar curvature</b> between the upper point and the point where the sail leaves the mast.....	10 mm

F.2.7 WEIGHTS

	minimum maximum
<b>Mast weight</b> .....	8 kg
<b>Corrector weights</b> .....	1 kg
<b>Mast</b> centre of gravity above heel, including halyard and shackle, with halyard hoisted and tail of halyard wound around mast below boom fork, with corrector weights but excluding boom pin.....	2400 mm

F.3 BOOM

F.3.1 CERTIFICATION

- (a) Each **boom** shall have its own identifying number, which may be incorporated with the **certification mark**.
- (b) The **official measurer** shall **certify booms** by fixing, signing and dating a **certification mark** on a side of the **boom** within 1 metre of the forward end.

- (c) The **certification mark** shall be a durable numbered sticker produced under the authority of the IFA, or an **official measurer's** personal mark.

F.3.2 MATERIALS

- (a) The **spar** shall be of wood; glass reinforced plastic, aluminium alloy or a combination of these materials.
- (a) Anodising and protective coatings are allowed.

F.3.3 CONSTRUCTION

The **boom spar** shall include a sail groove.

F.3.4 FITTINGS

(a) **Mandatory**

- (1) There shall be a hole, reinforced if necessary, to accept the boom pin.
- (2) There shall be a boom pin to attach the boom to the mast.
- (3) A distinctively coloured **spar band**.
- (4) **Corrector weights**, if fitted, shall be made of lead, and securely fastened to the outside of the boom within 1000 mm of the centre of the boom pin hole.

(b) **Optional**

- (1) Arrangements for attaching the mainsheet.
- (2) Arrangements for sail control lines and boom vang.
- (3) A fairlead where the sail leaves the **spar**.
- (4) A chafing pad beneath the outboard end of the **spar**.
- (5) Pads to protect the helmsman.

F.3.5 DIMENSIONS

minimum maximum

**Boom spar** cross section between 460mm and 3243 mm aft of the centre of the boom pin hole;

<b>vertical</b> .....	77 mm	...	82 mm
<b>transverse</b> .....	32 mm	...	37 mm
Boom Spar Curvature .....	5 mm		
Centre of boom pin hole below upper edge of boom .....	40 mm		
Diameter of boom pin hole.....	15.5 mm	..	16.5 mm
<b>Outer Point</b> from centre of the boom pin hole .....	3230 mm		
<b>Limit mark</b> width .....	13 mm		
Length of <b>sail</b> groove.....	2700 mm		

F.3.6 WEIGHTS

minimum maximum

<b>Boom weight</b> , including mast pin, blocks, boom vang outhaul and other fittings normally removed with the <b>boom</b> , but excluding mainsheet. ....	5 kg
<b>Corrector weights</b> .....	0.5 kg

(Blank Page)

### G.1.5 (b) - SAIL INSIGNIA



### G.1.3 and G.1.8 - SAIL MEASUREMENT

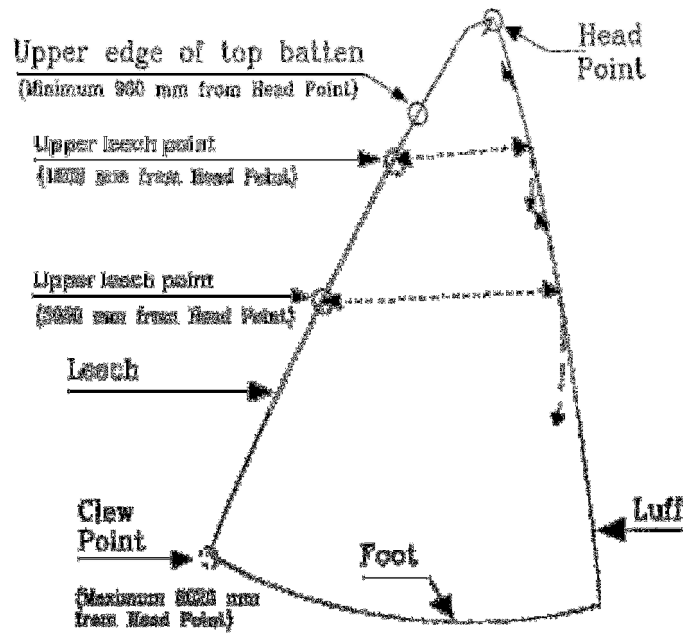

### G.1.3 (a) - UPPER LEECH POINT

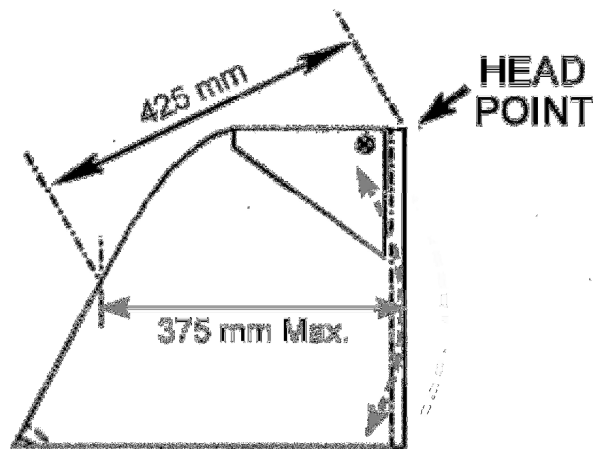

## Section G – Sail

### G.1 GENERAL

#### G.1.1 RULES

**Sails** shall comply with current **class rules**.

#### G.1.2 CERTIFICATION

- (a) An MNA may appoint one or more persons at a manufacturer to measure and **certify sails** produced by that manufacturer in accordance with ISAF guidelines.
- (b) **Sails** shall be measured by an **official measurer** before leaving the sail loft.
- (c) Every **sail** shall have a new sail label **certification mark** purchased by the sailmaker from IFA and permanently attached near the **tack**.
- (d) The **official measurer** shall **certify sails** by signing and dating the **sail** across the **certification mark**.

#### G.1.3 SAILMAKER

Rule D.2.3 applies to **sails**.

#### G.1.4 IDENTIFICATION

- (a) The national letters and sail numbers shall comply with the RRS.
- (b) The class sail insignia shall be two blue waves approximately 700 mm long. From left to right they shall go up, then down and up again. They shall be placed in accordance with Appendix G of the RRS.
- (c) The class insignia, national letter and sail numbers shall be made from additional material of contrasting colour, firmly attached to the sail. Painted class insignia, national letter and sail numbers are prohibited.

#### G.1.5 MATERIALS

- (a) The sail shall be made of flexible materials, which may be laminated.
- (b) Battens may be of any material.

#### G.1.6 CONSTRUCTION

- (a) The construction shall be: **soft sail, single ply sail**, with luff rope and foot rope.
- (b) Continuous layers or fibres crossing the seams are prohibited
- (c) The **sail** may have five **batten pockets** in the **leech**.
- (d) The following are permitted: **Seams**, stitching, glues, tapes, **tabling**, corner eyes, headboard with fixings, Cunningham eye or block, tack and Cunningham eye reinforcement, flutter patches, battens, **batten pocket patches**, batten pocket elastic, batten pocket end caps, headboard slides extending not more than 200mm down from the **head point**, track slides, leech line with cleat, Velcro fastening, tell tales, sail shape indicator stripes, sail identification, sailmaker labels.

G.1.7 DIMENSIONS

In alteration to ERS H.5.1, **sails** may be measured with the battens in position.

	minimum	maximum
<b>Leech length</b> .....		6020 mm
Distance from <b>Head Point</b> to any part of the sail.....		6050 mm
<b>Upper width at upper leech point</b> 3000 mm		
from the <b>head point</b> ** .....		1935 mm
<b>Upper width at upper leech point</b> 1500 mm		
from the <b>head point</b> ** .....		1075 mm
<b>Upper width at upper leech point</b> 425 mm		
from the <b>head point</b> ** .....		375 mm
** If there is a hollow at an <b>upper leech point</b> , this shall be added to the measured distance (see ERS H.5.2).		
<b>Top width</b> .....		165 mm
Width of <b>single ply</b> panels .....		1000 mm
<b>Head Primary reinforcement</b> , down from the <b>Head Point</b> .....		200 mm
<b>Clew Primary reinforcement</b> .....		350 mm
<b>Secondary reinforcement:</b>		
from <b>head point and clew point</b> (2 layers) .....		1000 mm
Depth of headboard from <b>head point</b> .....		200 mm
Width of headboard .....		150 mm
Thickness of headboard .....		20 mm
<b>Clew Point</b> to:		
aft end of <b>foot</b> rope .....		150 mm
forward end of <b>foot</b> rope.....		2500 mm
Batten lengths:		
Uppermost batten:.....		400 mm
second batten:.....		600 mm
third batten: .....		700 mm
fourth batten: .....		600 mm
lowest batten: .....		500 mm
Batten width:.....		50 mm
<b>Batten pocket width, inside</b> .....		50 mm
<b>Head point</b> to intersection of <b>leech</b> and upper part of uppermost batten .....		960 mm
Distance from lower part of a batten at the <b>leech</b> to the upper part of the batten below at the <b>leech</b> or to the <b>clew point</b> .....		900 mm

(Blank Page)

### H.1.3 SUITABLE FORMAT FOR MAST CARD

Supplier's Letterhead with any Logo, Address, Telephone, E-Mail etc.  
*Suppliers of International Finn Class Masts... etc. (not more than one line)*

**This is to Certify** that the Mast has been built in accordance with the current Rules of the International Finn Class, that the Mast Label has been correctly obtained from the International Finn Association, and that to the best of my knowledge and belief the mast has passed correct measurement from the authorized Measurer below.

**Signed** (Mast Manufacturer or Representative).....

**Date** ..... **Date of Manufacture** .....

### INTERNATIONAL FINN CLASS **MAST** MEASUREMENT CARD

F.2.2 (a) Measurer ..... Measurer's Signature .....

Measurer authorized by ..... Date of Certification Control .....

F.2.2 (b) IFA Mast Label attached ..... Number .....

F.2.3 **Materials** .....

F.2.3 (c) Material of the sail track.....

F.2.4 **Construction** ..... (complies)

F.2.5 **Fittings**..... (complies)

F.2.6 (a), (b) and (c) **Dimensions** ..... (complies)

F.2.6 (d) Other Dimensions..... (complies)

F.2.7 **Weight** with Correctors ..... (> 8 kg)

F.2.5 (a)(4) Position and fixing of corrector ..... (complies)

F.2.7 Corrector Weight ..... (< 1 kg)

Height of Corrector Weight..... (mm above **heel**)

**Mast** Centre of Gravity ..... (> 2400 mm above **heel**)

## PART III – APPENDICES

The rules in Part III are **closed class rules**. Measurement shall be carried out in accordance with the ERS except where varied in this Part.

### Section H

#### APPENDIX H.1. CERTIFICATE, MEASUREMENT FORM, MAST CARD AND CERTIFICATION MARKS.

##### H.1.1 CERTIFICATE

- (a) The **certificate** and attachment sheets shall be in the form annexed to these rules.
- (b) New **masts, booms, centreboards, rudders** and **sails** shall be **certified** as prescribed by rules A.15, B.1 and B.2.
- (c) Where alterations to the **certificate** are necessary due to changes or new equipment, obsolete items shall be crossed through and new entries made, if necessary on attachment sheets which shall be kept with the **certificate**.
- (d) Subject to rule A.15, the **certification** of older boats shall remain valid. Alterations, new weight information, other additions, and (where necessary) compliance with Section C of these rules shall be recorded on **certificate** or attachment sheets.

##### H.1.2 MEASUREMENT FORM

The Measurement Form for the **hull** and **centreboard** shall be in the form annexed to these rules. It shall be properly completed, and retained with the **certificate**.

##### H.1.3 MAST CARD

The Mast Card prescribed by rules A.11 and F.2.2 shall be in a form approved by IFA. A suitable format is shown. Manufacturers are invited to use the reverse side of the Mast Card to record the bend characteristics of the mast.

**APPENDIX H.2. DIAGRAMS.**

H.2.1 GENERAL DIAGRAMS RELATING TO MEASUREMENT EQUIPMENT  
(To be developed)

H.2.2 DIAGRAMS RELATING TO APPENDIX H.3 (LAMBOLEY SWING TEST)

**Diagram 20 - WEIGHT DISTRIBUTION**

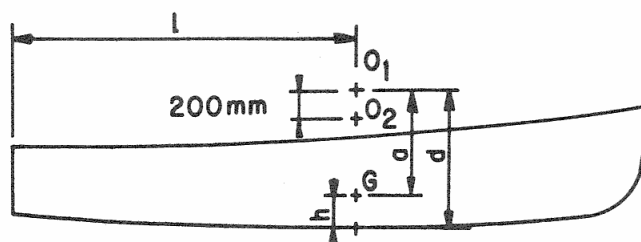

**Diagram 21 - SETTING UP OF BOAT FOR OSCILLATION**

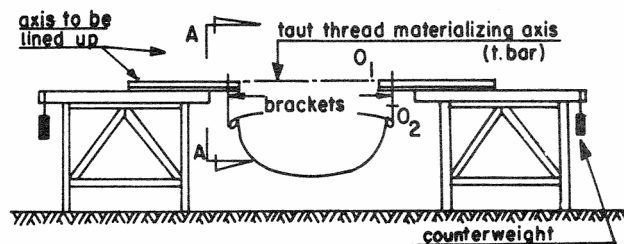

CROSS SECTION A

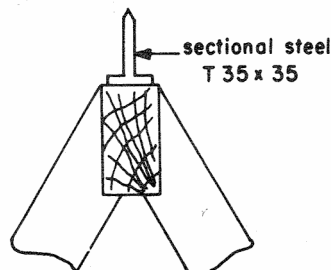

## Diagram 22 - Brackets

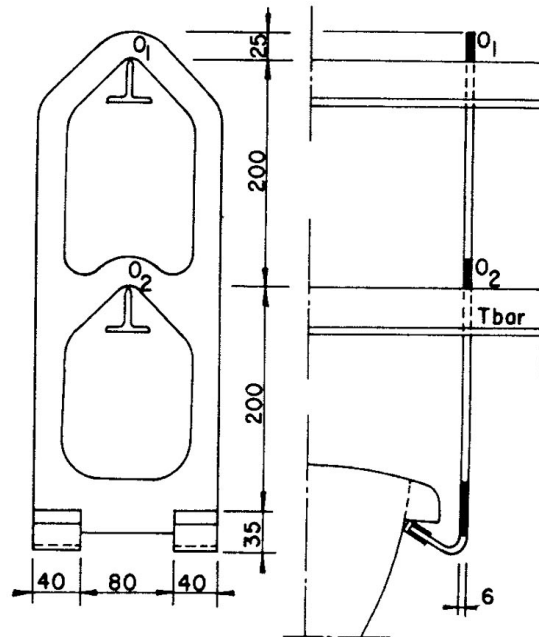

Material: Mild Steel

Mass (2 hooks): 2.70 kg min, 3.30 kg max

Detailed drawings are available and should be used for construction.

## Diagram 23

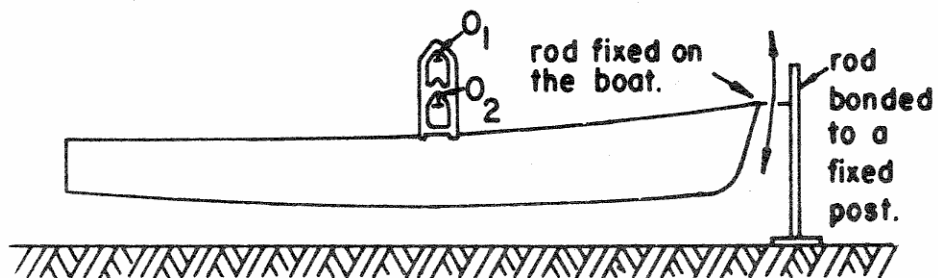
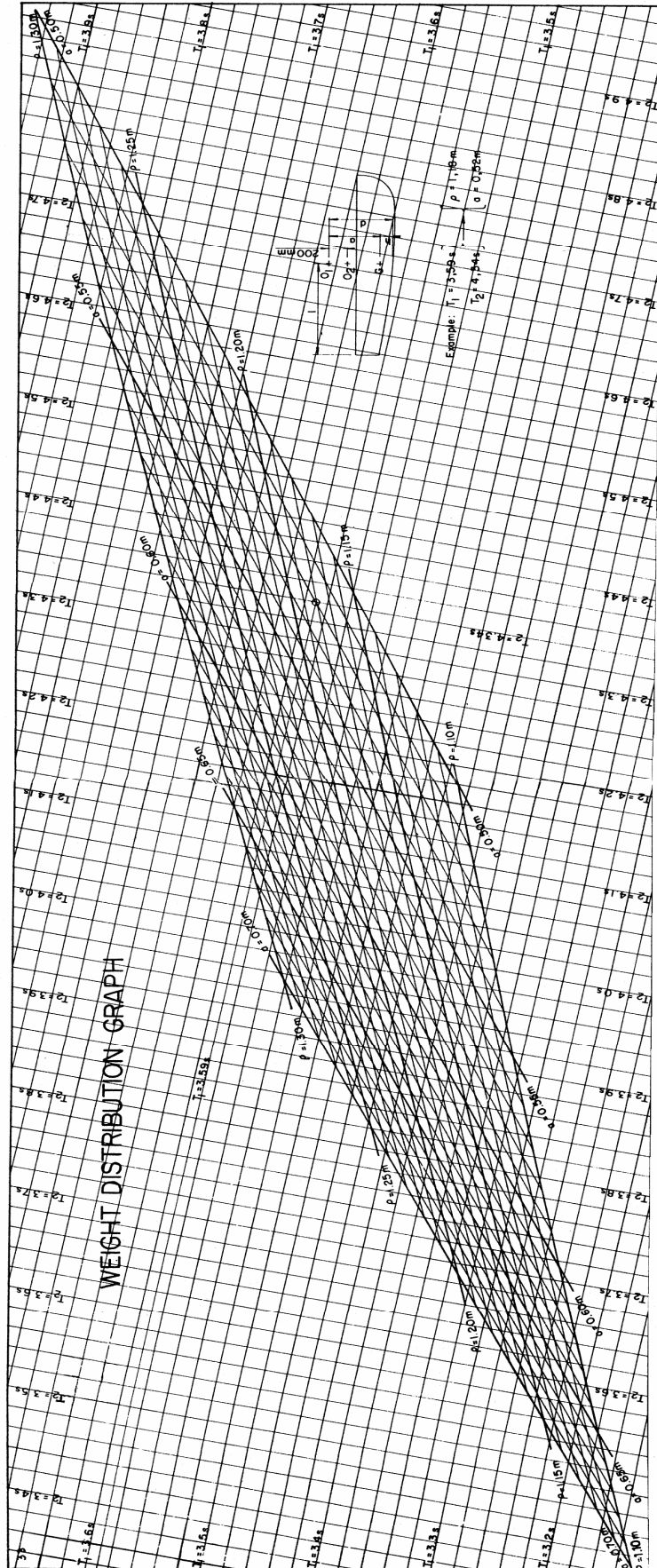

Diagram 24



## APPENDIX H.3

**WEIGHT DISTRIBUTION AND CENTRE OF GRAVITY: PRINCIPLES**

The degree of concentration of the weight in the boat is described by her radius of gyration. A boat with "light ends" has a short radius of gyration.

In Diagram 20, if "a" is the distance from the oscillation axis  $O_1$  to the centre of gravity G, "ρ" is the radius of gyration, and "g" is the acceleration due to gravity, then the oscillating period  $T_1$  is given by:

$$T_1 = 2\pi \sqrt{\frac{a^2 + \rho^2}{ag}}$$

We can measure T but we have two unknowns "a" and "ρ"; so we need two equations. Another is obtained by choosing a new oscillation axis  $O_2$  exactly 200 mm lower:

$$T_2 = 2\pi \sqrt{\frac{(a - 0.2m)^2 + \rho^2}{(a - 0.2m)g}}$$

Hence by measuring  $T_1$  and  $T_2$  we may calculate "a" and "ρ".

Solutions applicable to the Finn are presented in the graph (See Diagram 24).

The setting up of the axes  $O_1$  and  $O_2$  may be achieved with the equipment illustrated in diagrams 21 and 22. The brackets are designed to keep distance "a" short, to aid accuracy. The distance  $O_1 O_2$  shall be correct to within 1 mm. (See Diagram 20 to 24.)

**WEIGHT DISTRIBUTION AND CENTRE OF GRAVITY: PRACTICE**

It is essential that the measurements be made in a sheltered place. The boat shall be hung from the brackets on axis  $O_1$ ,  $O_2$  and the periods of oscillation  $T_1$ ,  $T_2$  measured.

Plot the position with co-ordinates  $T_1$ ,  $T_2$  on the graph, and read off the values for "a" and "ρ" from the curves. The distance "l" is measured parallel to base line from Station 0 to axis  $O_1$  (diagram 20). If "l" is found close to limit values make sure that base line is level as in the diagram at D.4. The distance "d" can usually be measured from axis  $O_1$  to the underneath of the hull (excluding keelband) by means of a rule or tape passed down through the centreboard box (diagram 20). If this is impossible, use the principle shown in diagram D.9.1 (Height of Mast Step). It is wise to provide a protection under the boat but the boat shall not touch anything while oscillating. The peak to peak movements of the bow shall remain between 200 mm and 160 mm during the time when the period of oscillation is measured. There shall be no twisting

oscillations about a vertical axis. There shall be no movement of the supports. The measurement of periods  $T_1$  and  $T_2$  requires most care. It is recommended to operate in the following way: two time keepers stand on either side of the boat, they shall start their stopwatches when the boat passes the rest position which is made easier with two rods placed opposite each other as in diagram 23; they count ten pitching periods and if they get the same result within 0.1s, the measurement is satisfactory (the result being thus 0.01s accurate).

Stopwatches accurate to 0.05s shall be used. If a stopwatch only accurate to 0.1s is used, twenty pitching periods shall be measured.

If correction is necessary to achieve permissible figures, record only the results obtained after correction.

(See Diagram 22 and 23.)

## ALTERNATIVES TO THE GRAPH

If preferred, a calculator may be programmed to obtain the values of "a" and "ρ".

*Pocket Calculator programme:*

Input  $T_1$  (sec)                      Input  $T_2$  (sec)  
 Input  $b=0.2$  (m)                    Input  $g$  (m/sec<sup>2</sup>)

$$\text{Calculate } k = \frac{g}{4\pi^2 b}$$

$$\text{Calculate } a = b \frac{kT_2^2 + 1}{k(T_2^2 - T_1^2) + 2}$$

$$\text{Calculate } \rho = \sqrt{abkT_1^2 - a^2}$$

Show or print  $a$  and  $\rho$  (m)

Check program with             $g = 9.81 \text{ m / sec}^2$      $T_1 = 3.31 \text{ sec}$      $T_2 = 3.81 \text{ sec}$

Result should be                 $a = 0.593 \text{ m}$      $\rho = 1.124 \text{ m}$

As another alternative, a simple Computer Spreadsheet can be constructed or obtained from IFA Technical Committee.

## APPENDIX H.4.

### CLASS RULES AMENDMENTS

- H.4.1 Proposals for amendments to these **class rules** may be submitted in time for circulation with the AGM Agenda, for consideration by IFA Council. Proposals may be submitted by IFA Executive members, by IFA Technical Committee and by NFAs.
- H.4.2 In cases of urgency the IFA Executive may prepare submissions to ISAF without prior reference to IFA Council. IFA Council must be informed and, at the next AGM, may require action as prescribed in H.4.3 or H.4.4.
- H.4.3 Where rule changes of major significance are proposed, the IFA Executive may decide to hold a referendum of all paid-up NFA members.
- H.4.4 If so directed by IFA Council, proposed amendments to these **class rules** shall be prepared by the Chairman of the Technical Committee and submitted to ISAF in accordance with ISAF Regulations.

### CLASS RULES INTERPRETATIONS

- H.4.5 The object of these rules is to establish a class of boats which is one-design in all matters that affect basic speed. The rules shall be interpreted in this spirit.
- Since it is unlikely that these rules can cover in detail every possible eventuality, builders are strongly advised to clear doubtful points with the IFA Technical Committee before starting construction.
- H.4.6 When points are referred to the Technical Committee, the T.C. Chairman shall:
- Provide an opinion; or
  - Consult with the Technical Committee, who shall interpret the rules. Technical Committee interpretations should be made by at least three members. If deemed appropriate, the interpretation should be submitted to IFA Council for ratification, and notified to ISAF for endorsement.
- H.4.7 The Technical Committee shall be guided by:
- The body lines and section plan, 1964.
  - The plans of the first carvel construction.
  - The digitised tables of coordinates for hull sections, stem and rudder profiles, and for templates.
  - The spirit of the rules.
  - Standard practice in the Finn Class.
- H.4.8 Where a builder or owner does not accept an interpretation of the Technical Committee, or a ratification by IFA Council, the matter shall be referred to the ISAF.
- H.4.9 On the Technical Committee's recommendation, to be ratified or altered by IFA Council or in urgent matters by the Executive Committee, the ISAF may give temporary or permanent dispensation, in which case the Measurer shall enter full details, signed and dated on the boat's Certificate.